

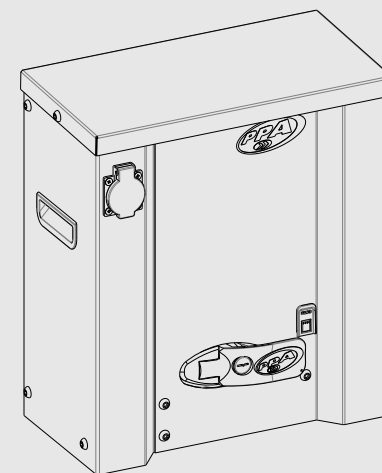

Technical Manual

# DZ BRUTALLE



**WARNING:**

Do not use the equipment without first reading the instruction manual.



Made by: **Motoppar Indústria e Comércio de Automatizadores Ltda**  
Av. Dr. Labieno da Costa Machado, 3526 - Distrito Industrial - Garça - SP - CEP 17406-200 - Brasil  
CNPJ: 52.605.821/0001-55

[www.ppa.com.br](http://www.ppa.com.br) | +55 14 3407 1000

P30452 - 04/2022  
Rev. 1

# INDEX

IMPORTANT SAFETY INSTRUCTIONS .....	4
TECHNICAL CHARACTERISTICS .....	5
TOOLS REQUIRED FOR INSTALLATION .....	6
ELECTRICAL INSTALLATION .....	6
CARE WITH THE ELECTRICAL INSTALLATION .....	7
GATE CARE BEFORE AUTOMATION .....	8
INSTALLATION AND FIXING OF THE OPERATOR .....	9
ANALOG LIMIT SWITCH INSTALLATION .....	14
MAINTENANCE .....	17

## IMPORTANT SAFETY INSTRUCTIONS



### Recommendation:

For the installation of the equipment, it is important that the PPA specialized installer follow all the instructions mentioned in this TECHNICAL MANUAL and in the USER MANUAL.

Equipped with the USER MANUAL, the installer must present all the information, uses and safety items of the equipment to the user.



Before using the operator, read and strictly follow all instructions contained in this manual.



-Before installing the operator, make sure that the local electrical network is compatible with that required on the equipment identification label;

-Do not turn on the mains until the installation / maintenance is completed. Make the electrical connections of the board always with the power grid turned off;

-After installation, make sure that the gate parts do not extend over the streets and the public footpath;

-The use of total shutdown devices is mandatory when installing the operator.

## TECHNICAL CHARACTERISTICS

DZ BRUTALLE 3.0T (Z12) (Z17)	
TYPE OF OPERATOR	Sliding
MODEL	JetFlex
RATED VOLTAGE	127V / 220V
NOMINAL FREQUENCY	60 Hz
RATED POWER	180W / 150W
ENGINE ROTATION	5800 RPM
NOMINAL CHAIN	1.7 A / 1.4 A
REDUCTION	1:50
LINEAR SPEED	Z12 = 26.3 m/min Z17 = 37.2 m/min
MANEUVERS	150 cycles/h
DEGREE OF PROTECTION	IPX4
TEMPERATURE RANGE	-5°C / +50°C
TYPE OF INSULATION	Class B, 130°C
LIMIT SWITCH	Hybrid (analog / digital)
MAX. MASS FROM THE LEAF OF THE GATE	Z12 = 3000 kg (6613lb) Z17 = 2500 kg (5511lb)
MAX. DIMENSION OF THE GATE	HEIGHT = 2.5 m LENGTH = 3.0 m

DZ BRUTALLE 2.0T (Z12) (Z17)	
TYPE OF OPERATOR	Sliding
MODEL	JetFlex
RATED VOLTAGE	127V / 220V
NOMINAL FREQUENCY	60 Hz
RATED POWER	205W / 190W
ENGINE ROTATION	5800 RPM
NOMINAL CHAIN	1.6 A / 1.1 A
REDUCTION	1:50
LINEAR SPEED	Z12 = 26.3 m/min Z17 = 37.2 m/min
MANEUVERS	70 cycles/h
DEGREE OF PROTECTION	IPX4
TEMPERATURE RANGE	-5°C / +50°C
TYPE OF INSULATION	Class B, 130°C
LIMIT SWITCH	Hybrid (analog / digital)
MAX. MASS FROM THE LEAF OF THE GATE	Z12 = 2000 kg (4409lb) Z17 = 1500 kg (3307lb)
MAX. DIMENSION OF THE GATE	HEIGHT = 2.5 m LENGTH = 10.0 m

## TOOLS REQUIRED FOR INSTALLATION

Below are some tools needed to install the operator:



## ELECTRICAL INSTALLATION

For electrical installation, the network must contain the following characteristics:

- Mains 127 V or 220 V;
- Have 5 A circuit breakers in the electrical energy distribution box;
- 3/4" diameter conduits between the electrical power distribution box and the total shutdown device;
- 3/4" diameter conduits between the total shutdown device and the operator connection point;
- 1/2" diameter conduits for external and optional push buttons;
- 1/2" diameter conduits for safety photocells (optional).

- ⚠** -The cable for fixed wiring must comply with NBR NM 247-3;
- The power conductor, of a product for internal use, must be a flexible cable 3 x 0.75 mm<sup>2</sup>; 500 V, according to the NBR standard NM 247-5;
- The power conductor, of a product for external use, must be a flexible cable 3 x 0.75 mm<sup>2</sup>; 500 V, as per the standard IEC 60245-57.

## CARE WITH THE ELECTRICAL INSTALLATION

To avoid damage to the wiring, it is important that all conductors are correctly attached to the operator. The passage of the wiring must be done through conduits, passing internally through the base of the floor, ensuring that none of the wiring conductors is trapped and damaged.

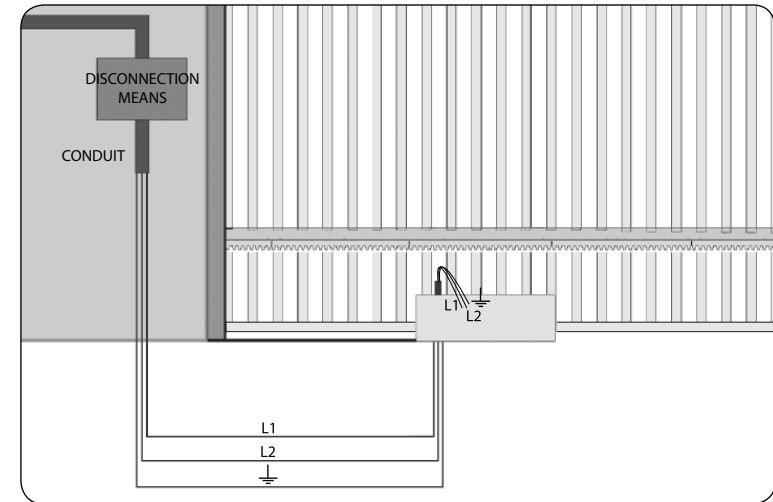

- ⚠** It is mandatory that the ground terminal be connected to the network ground cable.

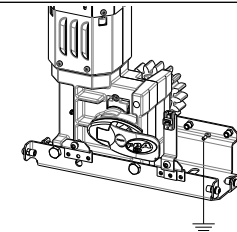

- ⚠ IMPORTANT**  
The instrument must be powered via a residual differential current (DR) device with a rated residual operating current exceeding 30 mA.

## GATE CARE BEFORE AUTOMATION

Before adapting the machine to the gate, check the slip, following the instructions below:

**1st Step:** Before installing the operator, check that the gate is in good mechanical condition, that is, opening and closing properly. Manually open the gate and note the effort required. This effort must be minimal along the entire length of the course.

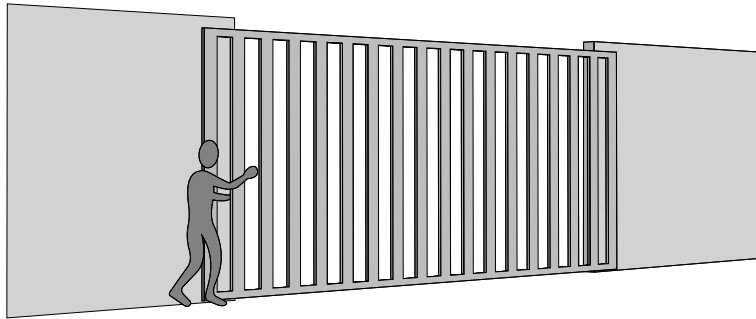

**2nd Step:** Close the gate manually and check if the effort exerted was equal to the previous operation.

The gate must have a strong structure and, as much as possible, non-deformable. The pulleys must have a diameter consistent with the dimensions of the gate, be in perfect rolling condition and mounted in such a way that the leaf the gate has stability throughout its displacement. We recommend pulleys with a minimum diameter of 120 mm.

The pictures below represent the two types of rails and pulleys used. The system that uses a straight section (Picture A - angle) presents greater friction and consequently greater wear. The circular section (Picture B) allows for better gate displacement and less friction for the operator.

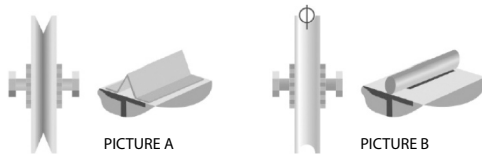

**3rd Step:** Check that the gate leaf does not get stuck in the opening and closing movement. The gate's sliding rail must be perfectly straight, level, periodically free of any element or dirt that makes it difficult for the pulleys to slide along their entire length, as shown in the figure below.

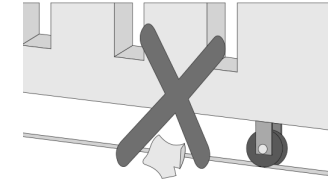

## INSTALLATION AND FIXING OF THE OPERATOR

Before installing the operator, remove all unnecessary cables and disable any equipment or system connected to the electrical network.

### EQUIPMENT DIMENSIONS

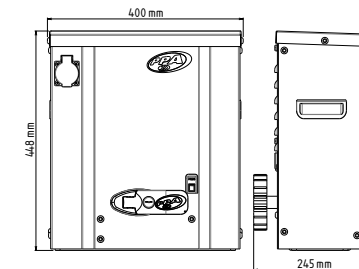

The perfect functioning of this equipment depends on the instructions contained in this manual. To secure the equipment, proceed as follows:

**1st Step:** Check that the floor is firm enough so that the equipment can be screwed so that it is level. If you do not comply with the requirement, provide a concrete base, following the guidelines below:

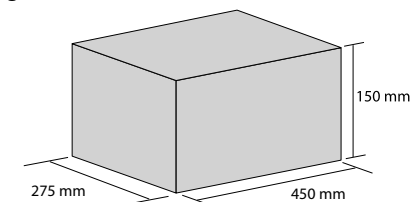

**2nd Step:** The dimensions of the base must be appropriate for the dimensions of the operator. The concrete base should be at a distance of approximately 20 mm from the face of the gate leaf.

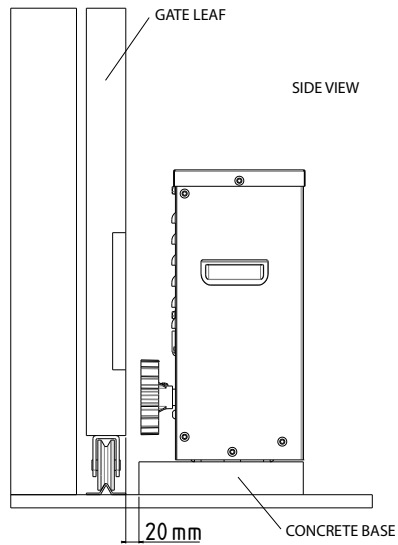

**3rd Step:** Once the conditions are attend, fully open the gate and position the operator close to the face of the gate leaf, obeying the 50 mm measurement between the leaf end and the concrete base.

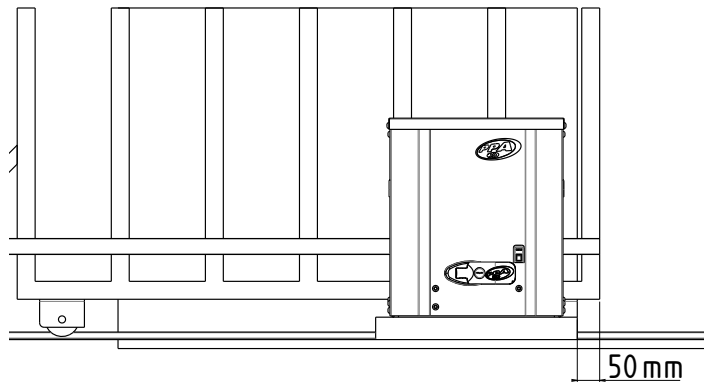

**4th Step:** Pre-align the operator to the gate, positioning the rack over the gear and leaning the set against the gate. Then mark the fixing holes in the floor or concrete base.

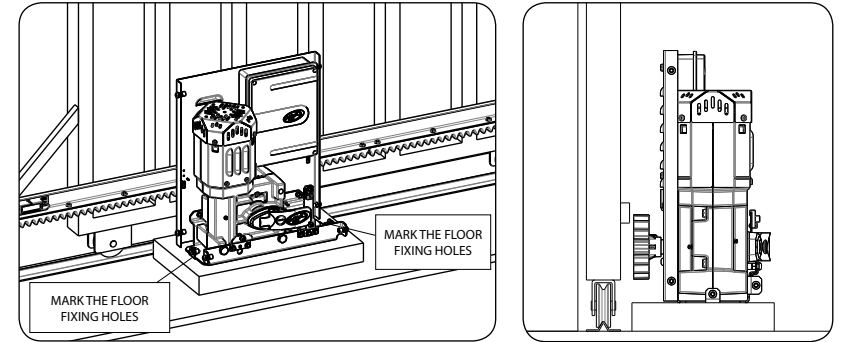

**5th Step:** Drill holes for fixing, positioning the operator aligned with the gate. Before tightening the 1/2" x 4" parabolts, move the gate, checking that it does not touch the operator during its journey. If this happens, back off the operator.

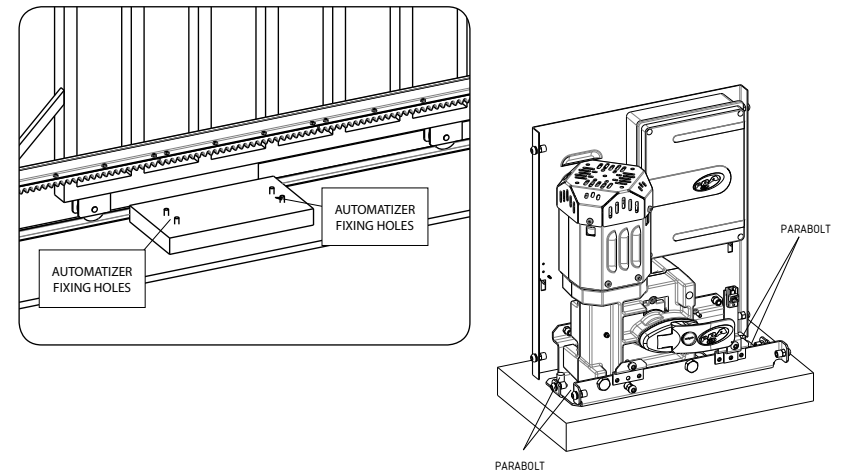

**6th Step:** With the operator unlocked, position the rack bar over the gear and aligned with the gate. It is necessary to leave approximately a 2mm gap between the top of the rack tooth and the bottom of the gear tooth.

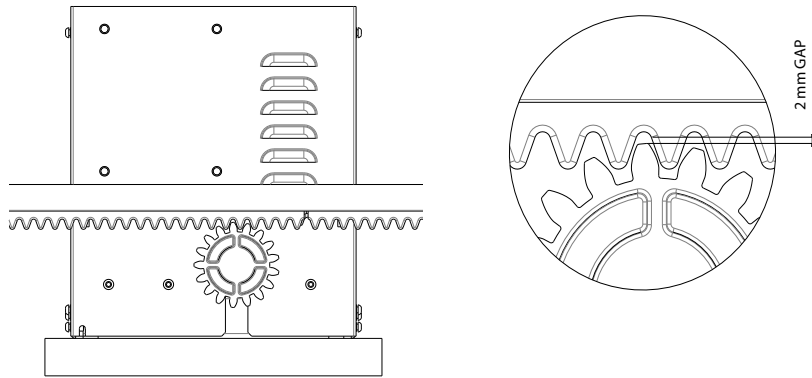

**7th Step:** Fix the rack along the entire length of the gate leaf with solder or screw every 300 or 400 mm.

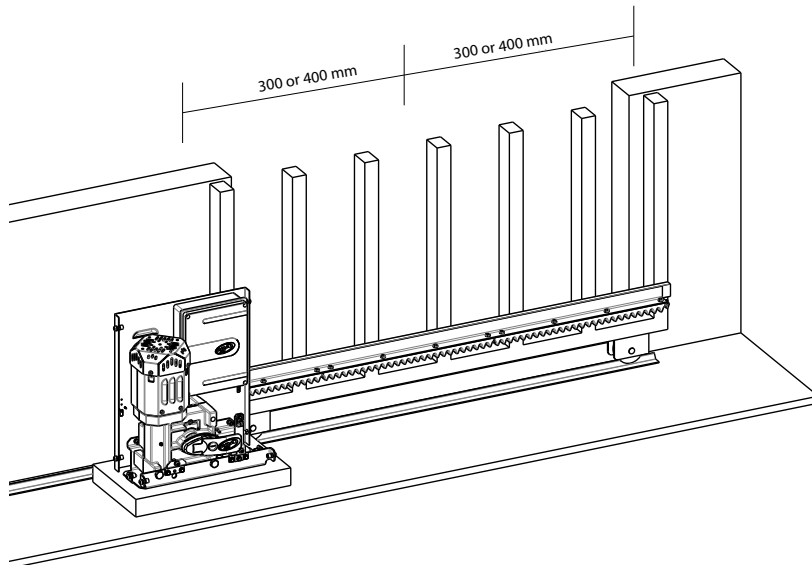

**8th Step:** If the gate leaf is warped, provide wedges to ensure rack alignment. There are cases where the rack will need to extend the length of the sheet. In this case, provide a French hand so that you do not jump your teeth when starting the machine.

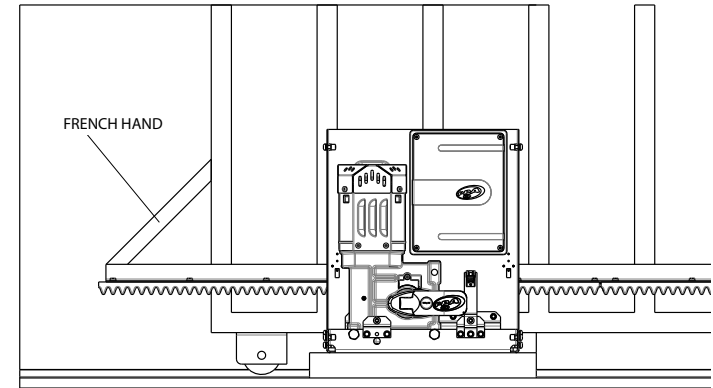

**9th Step:** After fixing the rack, permanently fix the operator on the floor or concrete base, tightening the screws permanently.

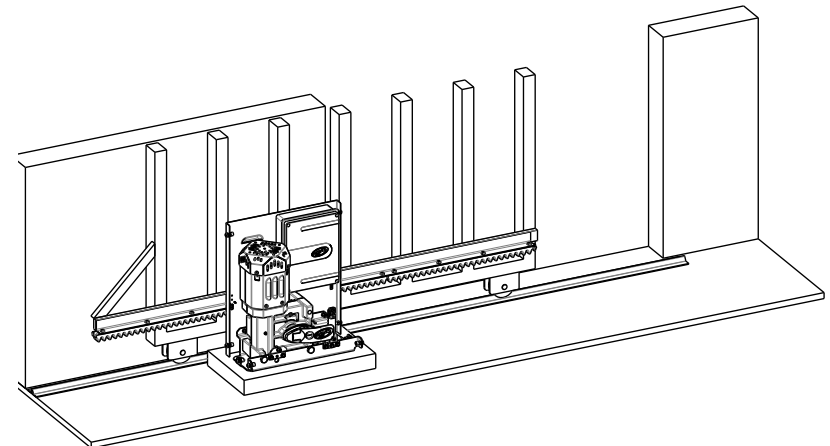

## ANALOG LIMIT SWITCH INSTALLATION

**1st Step:** With the gate closed, place the magnet support on the rack, positioned facing the operator's REED. This magnet will act as a closing limit switch.

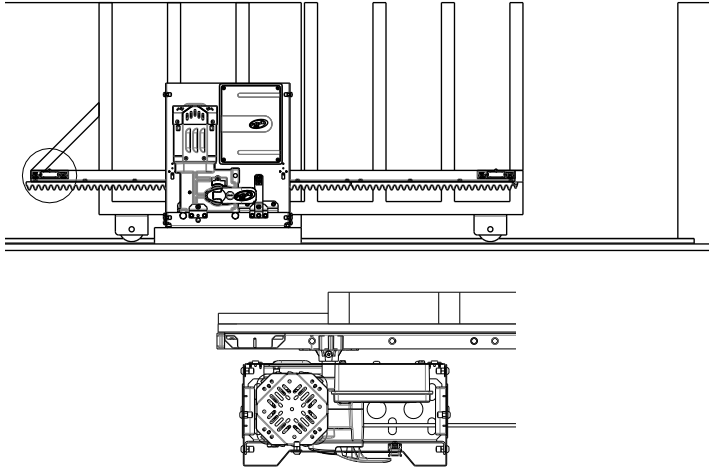

**2nd Step:** Fully open the gate and place the other magnet support on the rack, facing the operator's REED. This magnet will act as the opening limit switch.

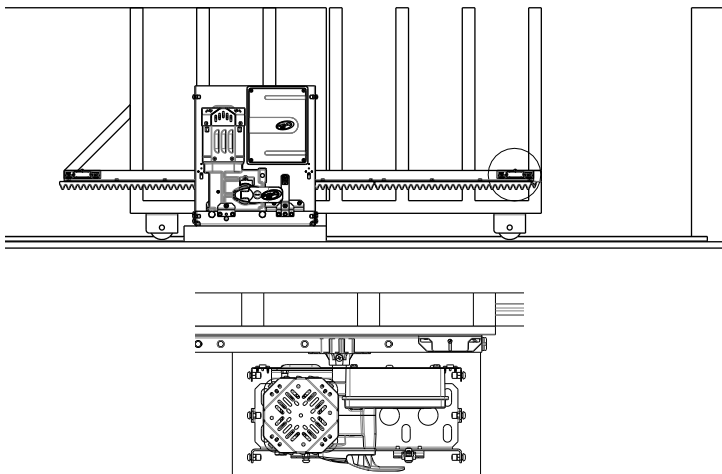

**3rd Step:** Start the engine and observe if the REED's are shutting down correctly. If necessary, invert the board connector. Once the magnet supports are fixed, make the final adjustments, moving them to the right or left, down or up, according to the desired adjustment.

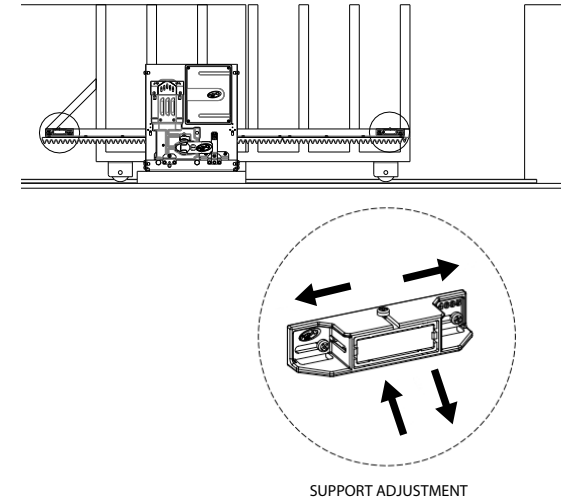

**4th Step:** To finish installing the operator, it is mandatory, before it works, to screw the fairing with 10 screws M8 x 20 mm.

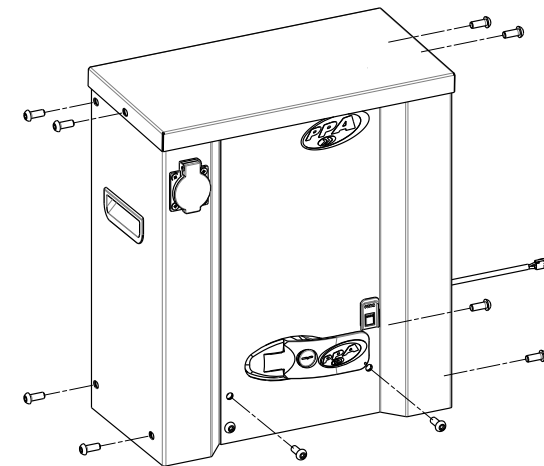

When connecting and using the outlet for operating external devices, the recommended is to use wire with a gauge of 2.5 mm<sup>2</sup> 110V or 220V.

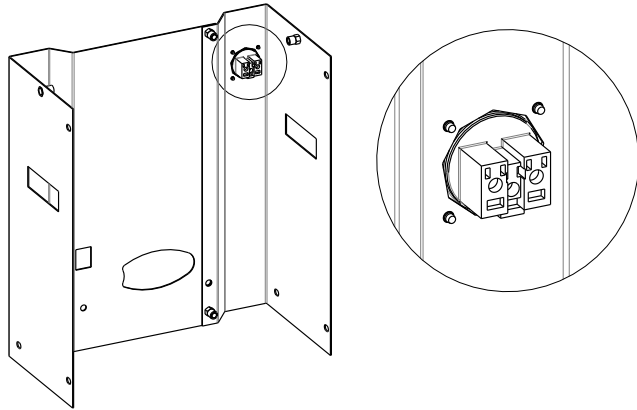

**COMMAND BOARD:**

Check the label attached to the product (according to the model on the side) which is the operator board. Once this is done, consult the board manual which is available for download at [www.ppa.com.br](http://www.ppa.com.br) and perform all connections and settings.

Lot:

Code:  
Model:  
Reduction:  
Technology:  
Voltage:  
Board:  
Size:  
Mounting:  
Fairing:  
Gear:



## MAINTENANCE

In the table below, some PROBLEMS will be mentioned — DEFECTS, PROBABLE CAUSES AND CORRECTIONS — that may occur in your Operator. Before any maintenance, it is necessary to completely disconnect the electrical network.

DEFECTS	PROBABLE CAUSES	CORRECTIONS
Motor does not start / does not move	A) Power off B) Open / blown fuse C) Locked gate D) Defective limit switch	A) Make sure the electrical network is connected correctly B) Replace fuse with same specification C) Make sure there is no object blocking the gate operation D) Replace the course end system (analog and/or digital)
Engine blocked	A) Inverted motor connection B) Locked gate or trigger	A) Check motor wires B) Put in manual mode and check separately
Electronics board does not accept command	A) Blown fuse B) Mains disconnected (power) C) Defect in remote control unloaded D) Transmitter range (remote control)	A) Replace the fuse B) Connect the network (power) C) Check and replace battery D) Check the position of the receiver antenna and, if necessary, reposition it to ensure reach
Motor only rotates to one side	A) Inverted motor wires B) Inverted limit switch system C) Defect in command board	A) Check motor connection B) Invert the connector at the limit switch (analog and/or digital) C) Replace the command board